

REV.	ECN NO.	LOCATION	DESCRIPTION	DATE	DESIGN
A			INITIAL RELEASE	2013.07.24	Lushifeng
B			CHANGE PART NUMBER DESCRIPTION	2013.09.03	Lushifeng

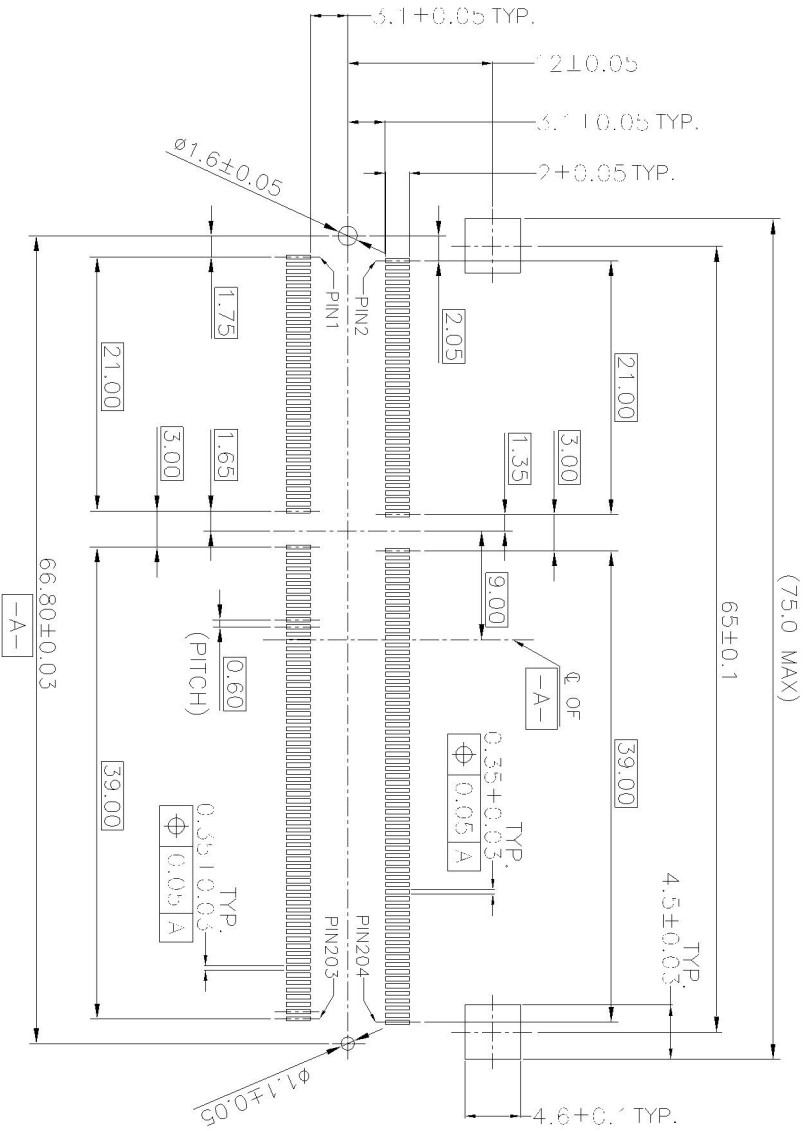

RECOMMENDED PCB LAYOUT

STANDARD TYPE

DIM		TOL		DIM		TOL	
X	X	±0.30	±2°	X	X	±1°	
X		±0.25					
.XX		±0.15					

REV.	B	DRAW NO.	T-11-0081
APPROVAL:	Linzongbao	DATE	2013.09.03

深圳市连欣科技有限公司		TITLE:	00R 50 DIMW PCB
CUSTOMER DRAWING	DATE	DESIGN:	Lushifeng
CHECK:		CHECK:	
APPROVAL:	Linzongbao	2013.09.03	

TRN/NO.	XDAP-4042044-20401
SHEET:	2/4
SCALE:	1:1
UNIT:	mm

E

D

C

B

A

1

2

3

4

5

6

7

8

E

D

C

B

A

1	2	3	4	5	6	7	8
---	---	---	---	---	---	---	---

REV.	ECN NO.	LOCATION	DESCRIPTION	DATE	DESIGN
A			INITIAL RELEASE	2013.07.24	Liushifeng
B		△ B	CHANGE PART NUMBER DESCRIPTION	2013.09.03	Liushifeng

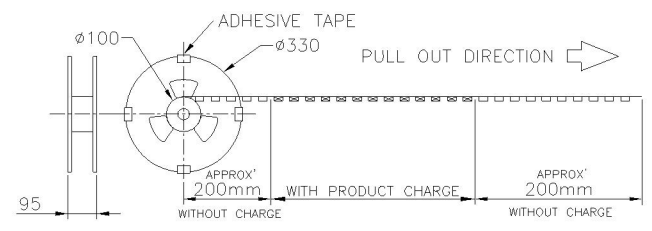

NOTES : (FOR TAPE & REEL)
 PACKAGING MATERIAL IN PLASTIC, RUBBER, INK, PIGMENT AND PAINT MUST MEET DEREN CONTROLLED SUBSTANCES SPEC.
 * CADMIUM AND CADMIUM COMPOUNDS NOT TO EXCEED:5 PPM.
 * LEAD, CADMIUM, CHROM VI AND MERCURY NOT TO EXCEED: 100 PPM (COMBINED).
 * CARRIER TAPES, COVER TAPES, REELS AND TAPED COMPONENTS MUST MEET THE REQUIREMENTS DEFINED PER EIA-481-B.

- MATERIAL :
 COVER TAPE : ANTISTATIC P.S, COLOR: TRANSPARENT COLOR.
 CARRIER TAPE : POLYSTYRENES.
 REEL : POLYSTYRENES.
 CARTON: CORRUGATED FIBER.
- QUANTITY : SEE TABLE
- WEIGHT : SEE TABLE
- PEELING RESISTANCE : 10gf~100gf (for 8mm)
 10gf~130gf (for 12mm~56mm)
 10gf~150gf (for 72mm)
- PEELING SPEED : 300mm/MINUTES

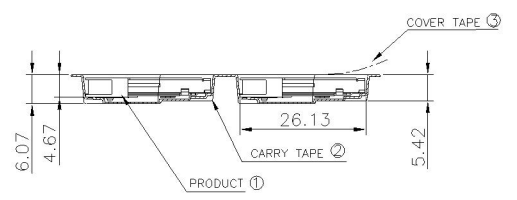
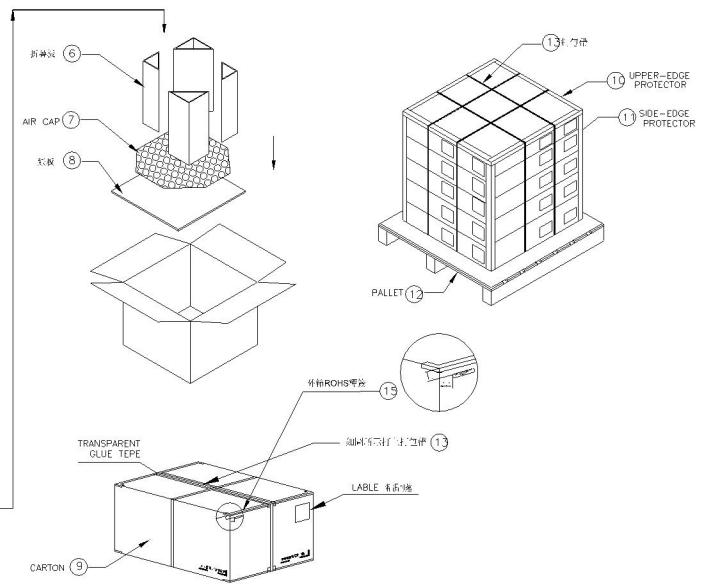
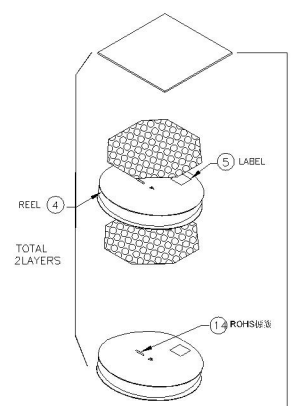
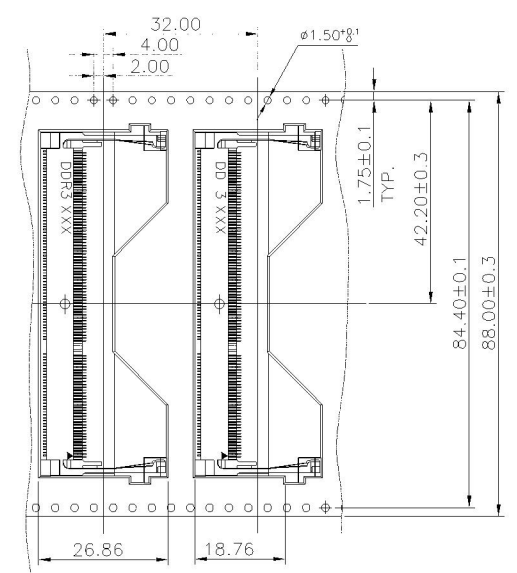

4.320KG	2.195KG	250	2
GROSS WEIGHT	NET WEIGHT	PCS/ REEL	REEL/ CARTON

DIM	TOL	DIM	TOL
x	±0.30	x	±2'
.x	±0.25	.x	±1'
.xx	±0.15		

深圳市连欣科技有限公司

DRAW NO. T-11-0081	DESIGN: Liushifeng	DATE: 2013.09.03	TITLE: DDR SO DIMM 5.2H ASS'Y PACKING
REV. B	CHECK: Linzongbiao	APPROVAL: Linzongbiao	DATE: 2013.09.03
PART NO: XDAP-4042044-20401		SHEET: 4/4	SCALE: 1:1
		UNIT: mm	

1	2	3	4	5	6	7	8
---	---	---	---	---	---	---	---