

HSF



REV.	ECN. NO.	DESCRIPTION	DATE.
1		初版发行	2020/09/25

NOTES:

- MATERIAL:
HOUSING: LCP BLACK UL94V-0;
TERMINAL: COPPER ALLOY /Au ON CONTACT AREA AND
SELECTIVE Au 1u" MIN SOLDERING AREA OVER Ni 50u" MIN.
SHELL: COPPER ALLOY /Au OVER Ni 50u" MIN.
- THE WARPAGE OF PRODUCT SHOULD BE NOT EXCEED 0.10mm.
- PLUG WITH PULL BAR USE AREA:
NO TRACE, NO TEST POINT, NO VIA HOLE, NO GROUND AREA.
- RECEPTACLE & PLUG USE AREA:
NO TRACE, NO TEST POINT, NO VIA HOLE, NO GROUND AREA ,
- PART NO: 20455-040E-02/12/22/66/76

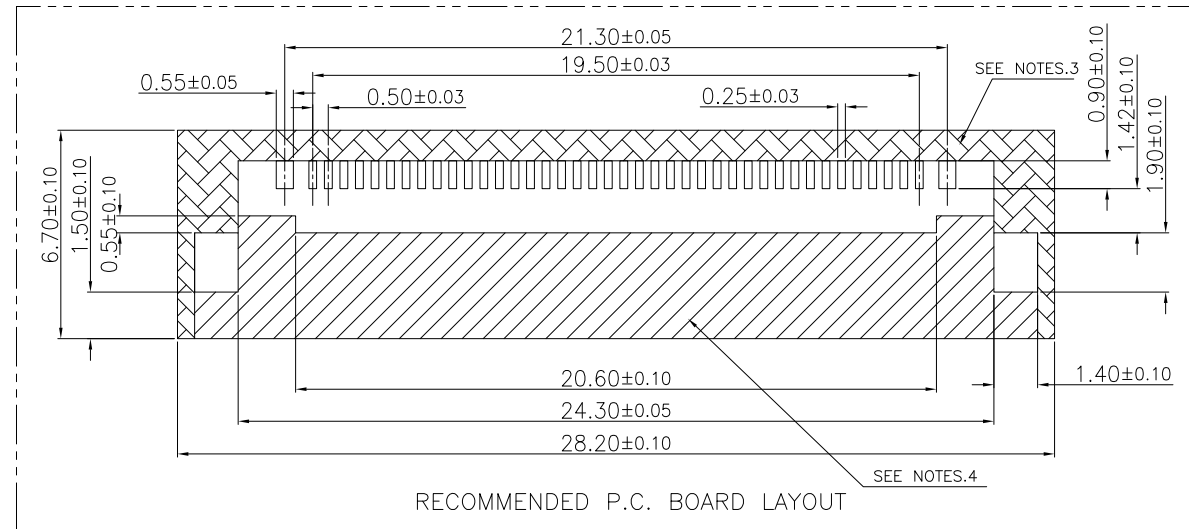
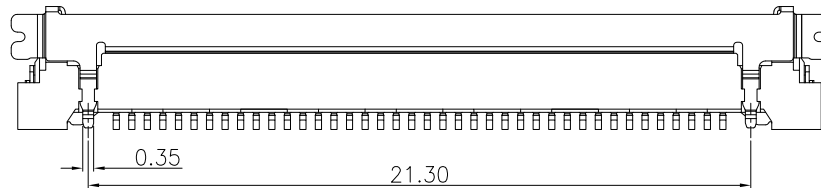
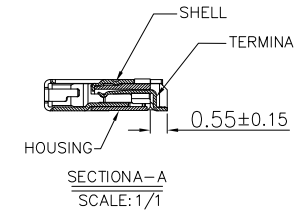
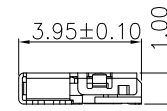
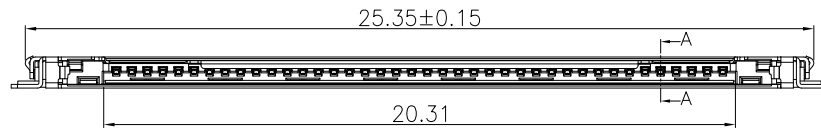
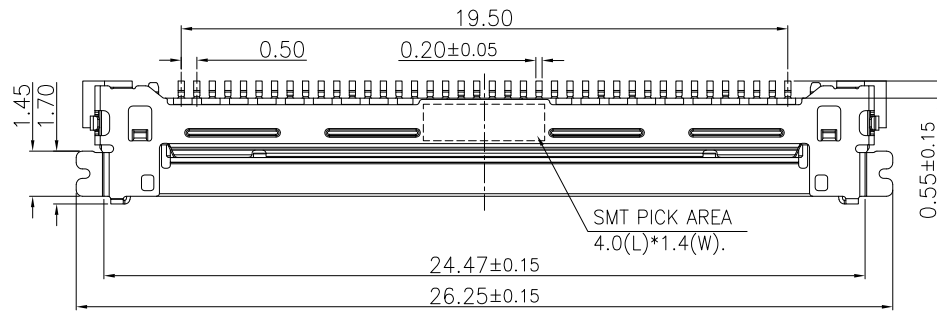

X. ±		X'. ±	Q'TY UNITS: Pcs	深圳市连欣科技有限公司		
.X ± 0.2		.X' ± 2'	PITCH: N/A			
.XX ± 0.1		.XX' ± 1'	MAT'L: N/A	20455-040E-**	LVDS CONN 0.5P 40CKT	
.XXX ±		.XXX' ±	FINISH: N/A	APP'D:	DWG No.:	
DIMENSIONS UNITS: mm		DATE: 2020/09/25		CHK'D: Martin	C-LV030-003	
				DR: fei	SCALE: N/A	
					SHEET: 1/1	
					REV: 1	