

RoHS Compliant

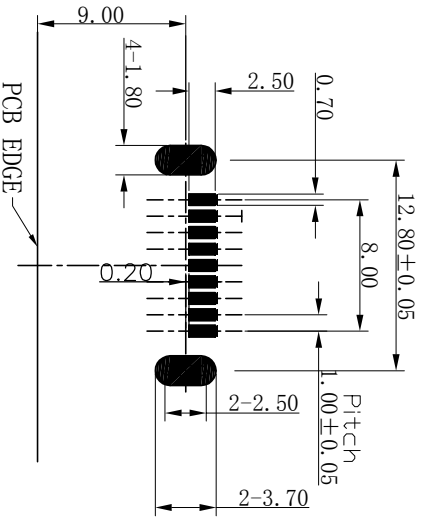

RECOMMENDED PCB LAYOUT
TOLERANCE: ±0.05mm

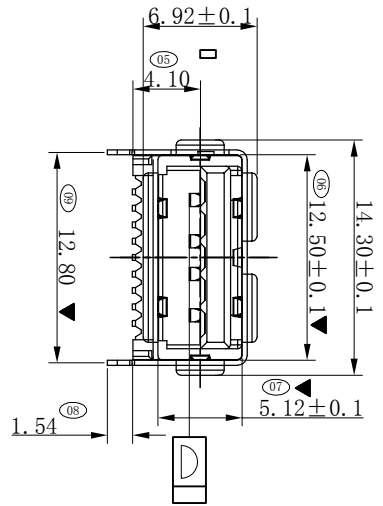
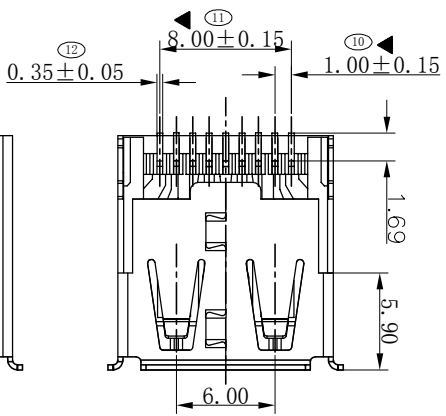
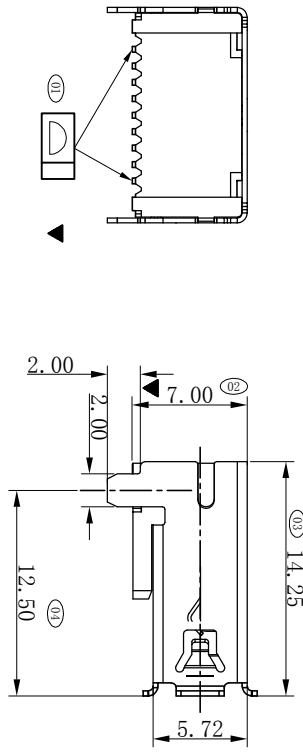
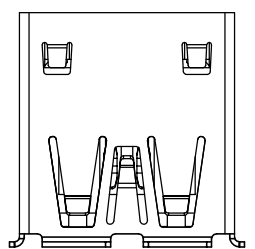

ECN. NO	REV	DATE	DESCRIPTION	CHANGED	APPROVED
	B	15.01.14	外观改连续板	James	
	A	14.09.05	NEW RELEASE	James	

= Pieces		TOLERANCES UNLESS		深圳市连欣科技有限公司 DATE: 2017.01.14 DESIGNER: James CHECKER:	
DIM NO.	⑩	K ± 0.50	K° ± 3°		
SCALE:	FIT	.XX ± 0.30	.X° ± 2°	DATE: 2017.01.14 DESIGNER: James CHECKER:	
SHEET:	1 OF 1	.XX ± 0.20	.XX° ± 1°		
UNIT:	mm	.XX ± 0.10	.XX° ± 0.5°	DATE: 2017.01.14 DESIGNER: James CHECKER:	
APPROVED:		DATE:			
PART NO:		DATE:		DATE: 2017.01.14 DESIGNER: James CHECKER:	
LX13SRF-036		LX13SRF-036			
SIZE:		DATE:		DATE: 2017.01.14 DESIGNER: James CHECKER:	
B		LX13SRF-036			